

Product Family Specification

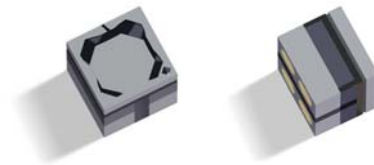

SCB10H Series
Pressure Elements

TABLE OF CONTENTS

1	General Description	3
1.1	Introduction	3
1.2	General Description.....	3
2	Capacitance - Pressure Relations.....	4
2.1	Parallel Plate Model	4
2.2	Capacitance - Pressure Behavior.....	5
2.3	Nonlinearity and Capacitance to Output Conversion.....	6
2.3.1	Linearization	6
2.3.2	Trimming and Linearity Performance.....	6
2.4	Temperature Dependency.....	8
2.5	How to Perform Calibration	8
3	Assembly Recommendations	9
3.1	Handling.....	9
3.2	Die Bonding and Environmental Protection.....	9
3.3	Protection of the Diaphragm.....	11
3.4	Electrical Contacting of the Element	11
3.5	ESD Protection.....	11
3.6	Contact Information.....	12

1 General Description

1.1 Introduction

This document contains technical and general guidelines how to design pressure sensor to various applications with SCB10H pressure elements.

1.2 General Description

The SCB10H pressure element consists of two silicon wafers and one glass wafer bonded together by anodic bonding. The other silicon wafer forms a diaphragm, which bends as a function of outer pressure inducing a force $F = (p_1 - p_2) \cdot A$. This force is proportional to the bending of the diaphragm, and hence to the capacitance between the electrodes ($C = \epsilon_r A / d$, where d = distance between the electrodes). Therefore the capacitance is a function of the outer pressure. The sealed gap between the static electrode and diaphragm contains argon gas at reference pressure p_2 .

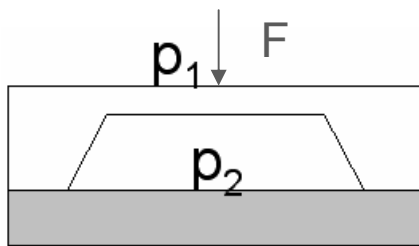

Figure 1. Capacitive absolute pressure sensor principle.

SCB10H series element has 3-dimensional structures which differentiate it from piezoresistive sensors for example. Thanks to this electrode insulation and capacitance dynamics are of their own class enabling better performance. The glass insulation used is relatively thick and therefore isolation resistance is high, which enables low leakage current and low stray capacitances. The relative capacitance change over the measuring range is typically 30 - 50% of the total capacitance. Due to this the changes in capacitance are easy to measure and give accurate results even at low current levels. In addition to this signal to noise ratios achieved are high. One considerable advantage over the other techniques is the high pressure endurance; the sensor element can withstand pressure significantly higher than the measuring range. For example, 1.2 bar element can be induced to pressure of 200 bar without any degradation in performance after the exposure.

Electrical model of the VTI pressure sensing element is presented in figure 2. Element and package related stray capacitances can be considered to be in parallel with pressure sensing part of the element. In case of over pressure the sensing element starts to behave as a resistor creating a DC connection between terminals SE1 and SE2. The serial resistance of the connection (R_{SC}) is a function of applied overpressure.

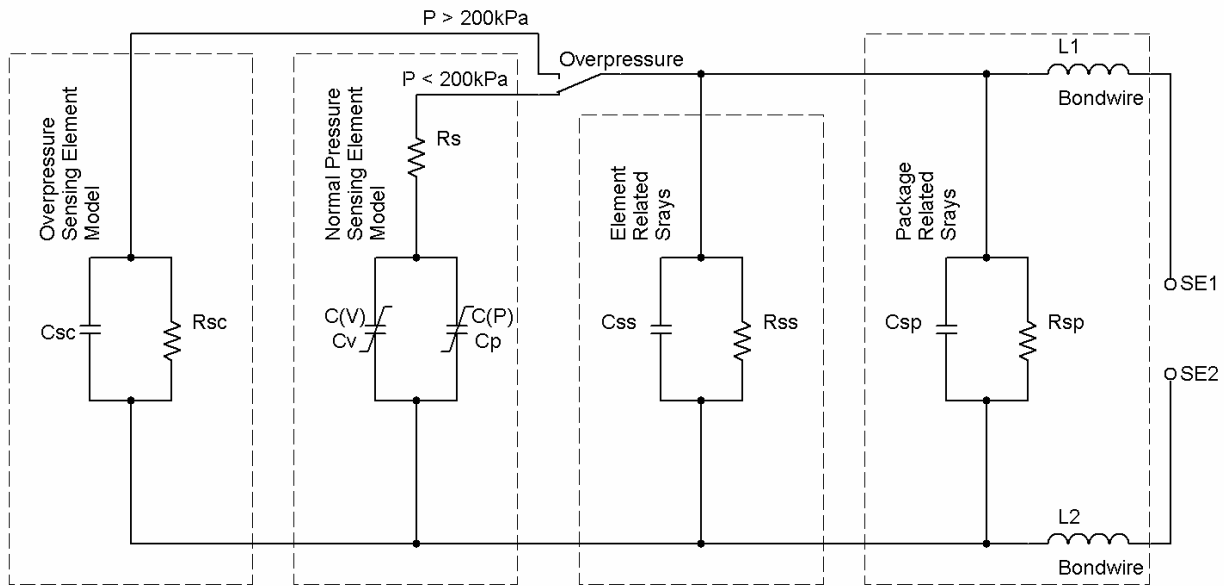

Figure 2. Electrical model of the SCB10H element.

2 Capacitance - Pressure Relations

2.1 Parallel Plate Model

Moving electrode (diaphragm) bends towards the stationary (inner) electrode with a certain curvature. This capacitance as a function of pressure can be modelled with a simplified parallel plate model

$$C(p) = C_{00} + \frac{C_0}{1 - p/p_0}$$

which can be further processed to multiple parallel plate capacitor model

$$C_{\text{model}}(p) = C_{00} + rC_0 + \frac{C_0}{1 - \frac{C_0}{K} p} + \frac{aC_0}{1 - \frac{C_0}{bK} p}$$

where the statistical variables C_{00} , C_0 and K are independent and vary from batch to batch and unit to unit with the lower and upper limits. Parameters r , a and b are constants for a given sensor type. C_{00} is stray capacitance of the sensor, C_0 is proportional to the inverse of distance between electrodes and p_0 is the pressure where electrodes touch each other. The specific parameter values are given in specifications. The pressure where plates touch each other is above the specified measuring pressure (this varies but for example with 1.2 bar element is typically around 1.4 bar). The sensor recovers fully from over pressure situations and measures as specified after pressure has been decreased to measuring range. In general, SCB10H series element can withstand very high pressures without any harm to performance or reliability. The elements have been induced to pressures up to 200 bars without any degradation of the properties.

The structure of SCB10H element is depicted in figure 3. The glass layer is between two single-crystal silicon layers and glass also insulates the bottom silicon wafer into two sections. By contacting onto these two sections (through bonding pads) electrical signal can be created both to the diaphragm (top electrode) and to the stationary plate (bottom electrode).

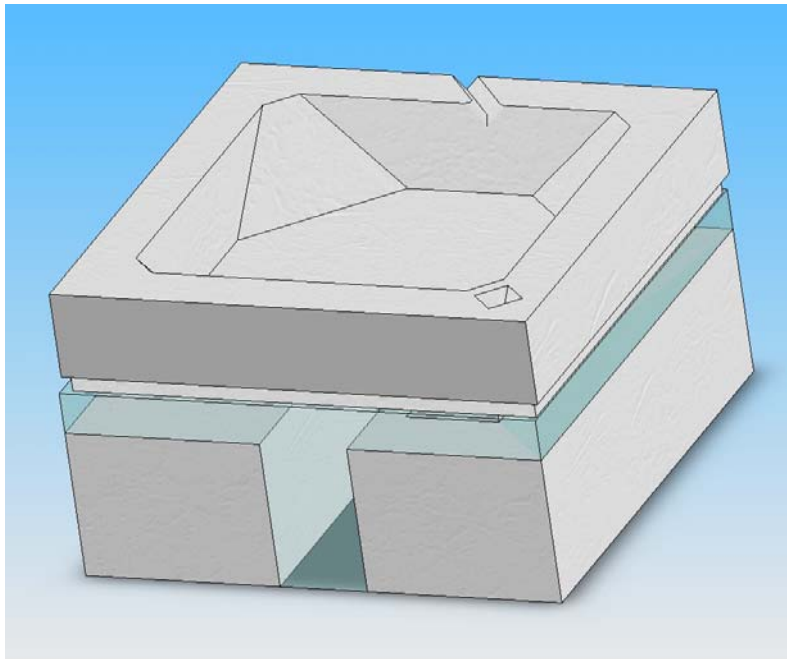

Figure 3. SCB10H element

2.2 Capacitance - Pressure Behavior

By performing simulations to above presented model using specification parameters capacitance - pressure dependency curve can be created. An example of such is presented below (1.2 bar SCB10H- series element).

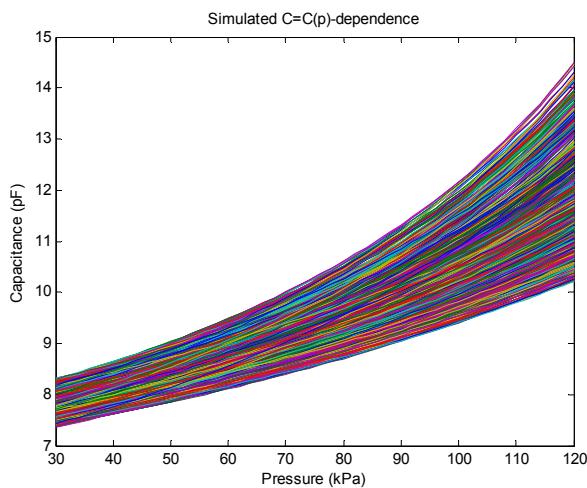

Figure 4. Simulated Capacitance - Pressure dependency for 1.2 bar sensor.

As can be seen the relation is non linear. Due to this the use of inverse of capacitance $1/C(p)$ is recommended,

$$p_a(C) = p_0 \left(1 + \frac{C_1}{C} + \frac{C_2}{C^2} + \frac{C_3}{C^3} \right)$$

since this is fairly linear function of pressure as can see from the curve below.

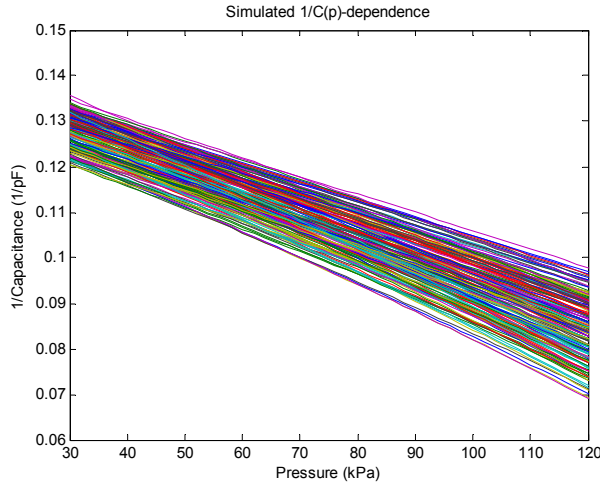

Figure 5. Simulated inverse of Capacitance - Pressure dependency for 1.2 bar sensor.

2.3 Nonlinearity and Capacitance to Output Conversion

The model presented here is accurate enough for calculating the application specific nonlinearity down to 0.1% FS. As in any application, a tradeoff has to be made with the number of calibration points, the number of included terms of the C(p)-dependence and the accuracy of the coefficients. VTI recommends to use circuit which gives 1/C(p) type output due to its relatively linear nature. In digital domain a polynomial calibration and linearization gives the best result.

2.3.1 Linearization

Polynomial calculation is the most commonly used method for linearization. Front-end should give a signal proportional to the inverse of the capacitance, and the calculation formula would be

$$p_{out} = p''_0 \left(1 + c''_1 \left(\frac{1}{C(p_{in})} \right) + c''_2 \left(\frac{1}{C(p_{in})} \right)^2 + \dots \right)$$

With a suitable cut-off in the number of terms included. Using three coefficients p''_0 , c''_1 and c''_2 should result in an acceptable performance for most applications.

2.3.2 Trimming and Linearity Performance

Depending on performance requirement different calibration sequences can be selected. By increasing the number of calibration points the performance can be increased. Using full model linearization and selecting the calibration points so that the total error over the pressure range is minimized the pressure errors presented in the table and figures below can be achieved (an example for 1.2 bar the element). Temperature dependencies are not included here.

Calibration Product 1.2 bar element	Typ error @ 30 kPa (kPa)	Typ error @ 60 kPa (kPa)	Typ error @ 90 kPa (kPa)	Typ error @ 120 kPa (kPa)
2 point (1 st degree polynomial)	0.9	0.6	0.8	0.9
3 point (2 nd degree polynomial)	0.03	0.03	0.02	0.03
4 point (3 rd degree polynomial)	0.002	0.0002	0.002	0.004

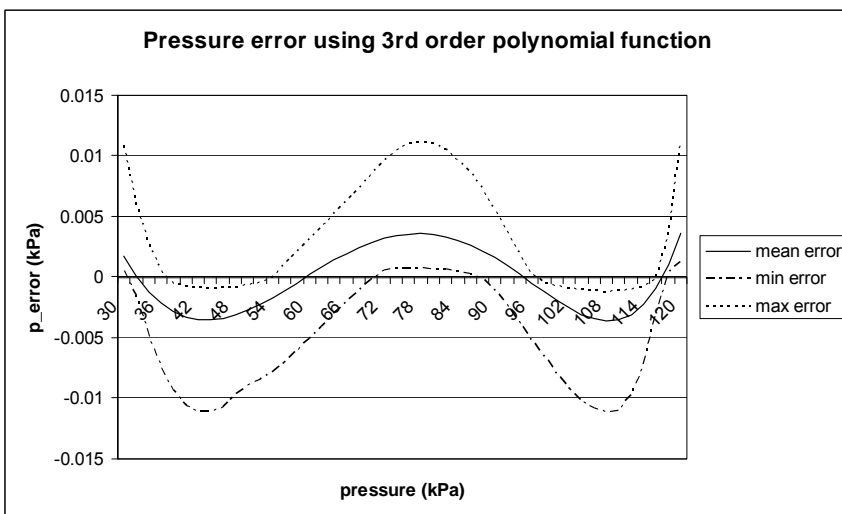
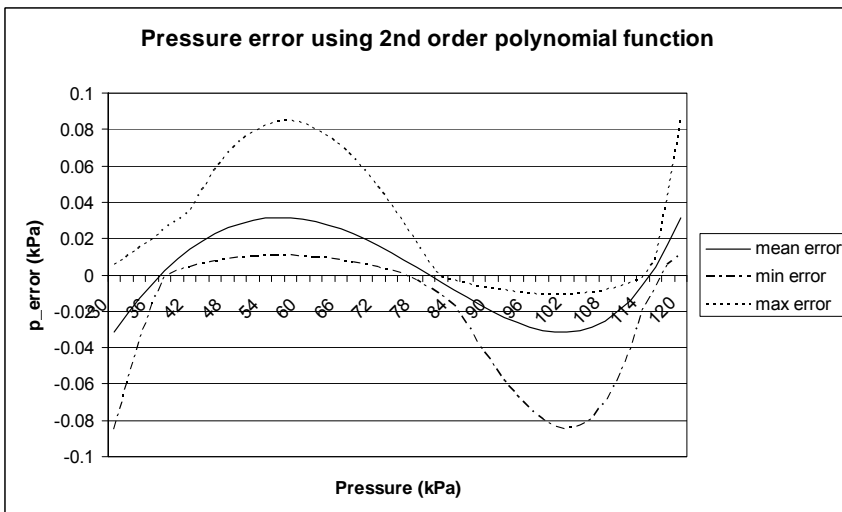
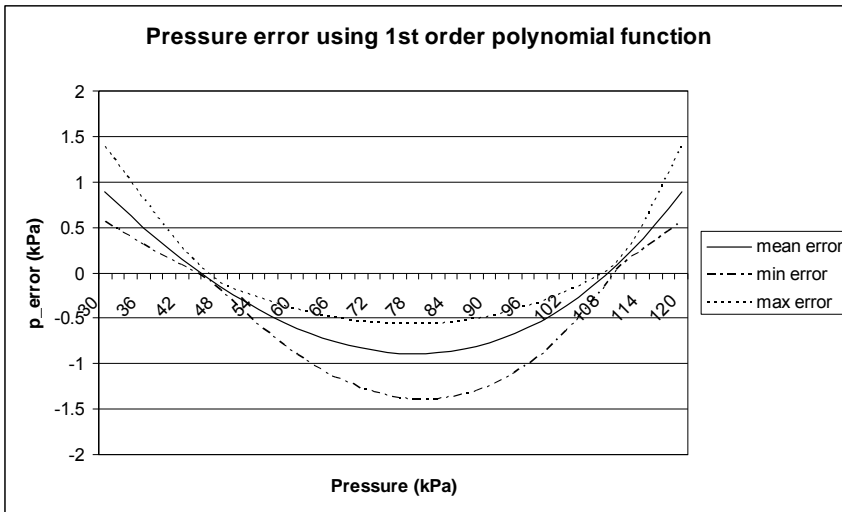

Figures 6-8. Performance over pressure using various calibration functions.

2.4 Temperature Dependency

In addition to pressure capacitance is also dependent on the temperature. If the application requires high accuracy over large temperature range calibration over temperature is recommended. On the other hand, applications operating at narrow temperature range can efficiently be calibrated at operating temperature without need for temperature compensation. Packaging induced mechanical stress has a great effect on temperature dependency and it is very important to take this into account in the product design.

The pressure error has a second order dependency on temperature and is of form

$$p_{\text{comp}}(p, T) = \alpha(T) + \beta(T) \cdot (p - p_{\text{ref}}),$$

where $\alpha(T)$ and $\beta(T)$ can be written as a polynomial expansion

$$\alpha(T) = \alpha_1 \cdot (T - T_{\text{ref}}) + \alpha_2 \cdot (T - T_{\text{ref}})^2$$

and

$$\beta(T) = \beta_1 \cdot (T - T_{\text{ref}}) + \beta_2 \cdot (T - T_{\text{ref}})^2.$$

Function $\alpha(T)$ describes the temperature dependency at constant pressure $p = p_{\text{ref}}$ and function $\beta(T)$ describes the temperature dependency of sensitivity. By definition, $p_{\text{comp}}(p, T = T_{\text{ref}}) = 0$. Parameters α_1 and β_1 can be identified as the temperature coefficient of offset (TCO) and sensitivity (TCS), respectively.

The temperature dependency of the sensing element expressed in pressure units can be calculated from the two previous functions

$$\frac{dp}{dT} = \frac{d\alpha(T)}{dT} + \frac{d\beta(T)}{dT} \cdot (p - p_{\text{ref}})$$

In the table below some examples of performance using different calibration sequences are presented for 1.2 bar pressure element.

Table: Pressure error for 1.2 bar sensor in the temperature range of -10 - 80 °C with various calibration sequences using 3rd order linearization over pressure

Number of calibration points over temperature	Max error w/o temperature compensation (kPa)	Max error w/ temperature compensation (kPa)
4	0.6	0.0004
2	0.6	0.26

2.5 How to Perform Calibration

The temperature and pressure dependent output pressure can be described with a function:

$$p_{\text{out}} = p_{\text{out}}(C_{\text{in}}, T) = p_{\text{lin}}(C_{\text{in}}) - p_{\text{comp}}(p_{\text{lin}}(C_{\text{in}}), T),$$

where the function p_{lin} does the linearization from capacitance to pressure at reference temperature T_{ref} and C_{in} is the measured capacitance. P_{comp} is the temperature compensation function and T is the temperature calibration point.

One way to perform calibration is to measure over needed pressure range at certain selected pressure points at reference temperature (usually 25 °C) and then perform linearization according to selected method. After this to carry out temperature compensation at selected temperature points using already calculated pressure dependency as a background.

3 Assembly Recommendations

3.1 Handling

Sensor element is ESD sensitive and allowed ESD levels are 60 V of Human body model and 40 V of Machine model. Pressure sensing diaphragm is also mechanically sensitive and due to these features metallic tweezers are not to be used in handling. During chip handling process the die bonder nozzle must cover the whole chip.

3.2 Die Bonding and Environmental Protection

The general guideline is to use soft adhesives and soft materials (low modulus materials) with products that utilize SCB10H pressure element. Silicone adhesives have been used to attach the element onto substrate and electrical contacts have been realized through wirebonding. It is particularly important to pay attention not to generate high stress to the element especially in applications requiring high performance. Due to this, soldering of SCB10H element is not recommended. Stiff joint generates high stress to the element causing mechanical dimensions to change and therefore affecting the measured capacitance. Conductive adhesives have also been tested, but with these as when soldered it is important to take into account the mechanical stresses possibly induced with harder materials. In the table below some examples of hysteresis behaviour over temperature are depicted.

Table: The hysteresis behaviour of different assemblies.

Construction	Hysteresis mean from high temperature (about 60 °C) to room temperature
soldered on alumina	1.1 kPa
soldered on FR-4	4.8 kPa
wirebonded on alumina	0 kPa
Ag filled silicone	0 kPa
Ag filled flexible epoxy	0.1 kPa
conductive polymer	0.5 kPa

In the following pictures some possible ways to assemble SCB10H series pressure elements are described. FR4, ceramic or other material, with 1.8 mm x 1.8 mm cavity has been used as a substrate and the element is placed diaphragm downwards in the cavity. A tape that can withstand higher temperatures is placed under the substrate during assembly process.

VTI recommends silicone based soft adhesives which have been dispensed around the element. Hard adhesives, such as epoxies, are like solder and can create stresses against the sensor element and the performance of the system can be decreased.

It is important to protect glass - silicon interface because humidity on glass surfaces may cause measurement error by introducing an additional electrical leakage current path between silicon parts. In the worst case conductive fluids can cause a short circuit. Therefore protection at least to the level of upper horizontal glass - silicon interface is recommended (picture 9a). The other possible ways to assemble SCB10H element in the hole are depicted in pictures 9b) and 9c). From performance point of view the approach presented in picture 9a) is preferred, because it causes the smallest mechanical stress. But it also has to be taken care that it can withstand the possible overpressure situations.

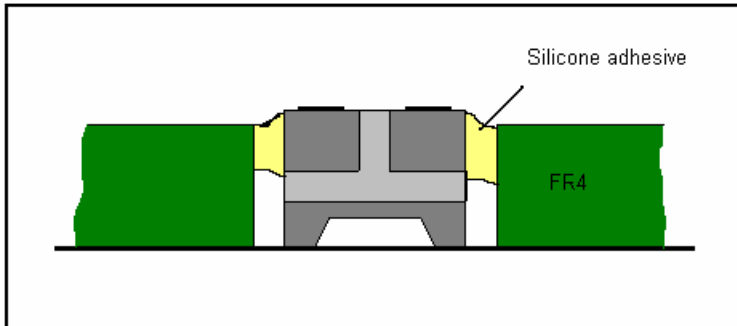

Picture 9a. Cross section of die bonding. Silicone adhesive insulates the interface between contact pad wafer and glass.

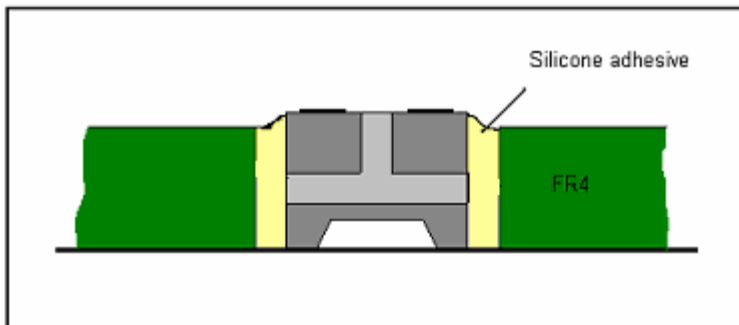

Picture 9b. Cross section of die bonding. Silicone adhesive is on all vertical surfaces.

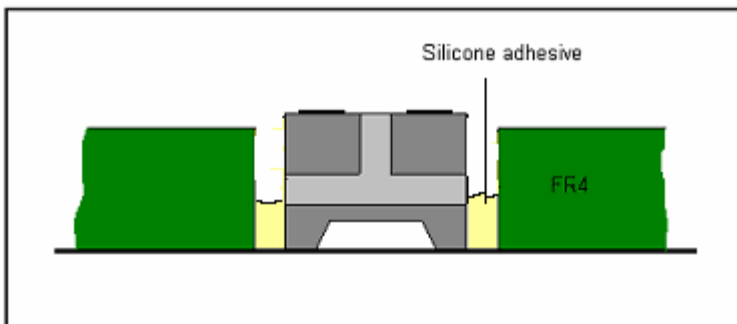

Picture 9c. Cross section of die bonding. Silicone adhesive insulates the interface between diaphragm wafer and glass.

3.3 Protection of the Diaphragm

No protection on element diaphragm is needed if product is to be used in dry, non corrosive gas and/or measuring electronics is designed so that it can tolerate the possibly resulting signal paths by conductive fluids. However, in order to minimize the amplification of stray electric field on the sensor element by foreign dielectric, protection of the sides of the element at least to the level of upper horizontal glass - silicon interface is recommended (picture 9a) as discussed in the previous chapter.

In all material selection it is important to consider materials that generate as little as possible mechanical stress to the element. Repeatable and minimum thermal error can be obtained using a silicone materials. The requirement of pressure cycling can set the limits for materials also. Silicone gels tend to bubble at high pressures and therefore their use can also be limited by application environment.

3.4 Electrical Contacting of the Element

In order to obtain best performance wirebonding is recommended over soldering due to reasons already discussed above. Recommended wire bonding method for SCB10H series elements is thermosonic Ball – Wedge on Au bump (SSB). For optimal result either ball bond or Wedge on bump is recommended on sensing element pads. Wedge – wedge bonding with either Au or Al is also possible. Generally higher frequencies, for example 120 kHz, are recommended.

3.5 ESD Protection

The sensor element is an ESD sensitive device and proper ESD precautions are needed to avoid performance degradation or loss of functionality. After assembly, protection against ESD should be provided by the measurement electronics.

3.6 Contact Information

<p>Finland (head office) VTI Technologies Oy P.O. Box 27 Myllynkivenkuja 6 FI-01621 Vantaa Finland Tel. +358 9 879 181 Fax +358 9 8791 8791 E-mail: sales@vti.fi</p>	<p>Germany VTI Technologies Frankfurt Branch Eschborner Landstrasse 42-50 D-60489 Frankfurt am Main T Germany Tel. +49 69 6786 880 Fax +49 69 6786 8829 E-mail: sales.de@vti.fi</p>	<p>USA VTI Technologies, Inc. 70 South Lake Ave., 10PthP Floor Pasadena, CA 91101 USA Tel. +1 626 463 7011 Fax +1 626 463 7013 E-mail: sales@vtitechnologies.com</p>
<p>Japan VTI Technologies Oy Tokyo Office Tokyo-to, Minato-ku 2-7-16 Bureau Toranomom 401 Tokyo 105-0001 Japan Tel. +81 3 6277 6618 Fax +81 3 6277 6619 E-mail: japan.sales@vti.fi www.vtitechnologies.jp</p>	<p>China Beijing VTI Sensor Co., Ltd. Unit 705, 7/F, The Exchange Beijing B-118, Jian Guo Road Chaoyang District Beijing 100022 P.R. China Tel. +86 10 6484 6053 Fax +86 10 6484 6052 E-mail: china.sales@vti.fi</p>	<p>To find out your local sales representative visit www.vti.fi</p>