

Data Sheet



SCA2120-D07 2-AXIS ACCELEROMETER WITH DIGITAL SPI INTERFACE

Features

- 3.3V supply voltage
- ± 2 g measurement range
- 2-axis measurement YZ directions
- ± 50 mg offset accuracy over temp range
- Internal temperature sensor
- SPI digital interface
- Enhanced self diagnostics features
- Size 7.6 x 3.3 x 8.6 mm (w x h x l)
- Qualified according to AEC-Q100 standard
- Package, pin-out and SPI protocol compatible with VTI digital accelerometer product family
- RoHS compliant Dual Flat Lead (DFL) plastic package suitable for lead free soldering process and SMD mounting
- Proven capacitive 3D-MEMS technology

Applications

SCA2120-D07 is targeted to automotive applications.

Typical applications include

- Electronic Stability Control (ESC)
- Hill Start Aid (HSA)
- Electronic Parking Brake (EPB)
- Roll Over
- Suspension
- Inclination
- Industrial applications

General Description

SCA2120-D07 is a two axis accelerometer component based on VTI capacitive 3D-MEMS technology. The component integrates high accuracy micromechanical acceleration sensing together with a flexible SPI digital interface. Dual Flat Lead (DFL) housing of the component guarantees robust operation over the product lifetime.

SCA2120-D07 is designed, manufactured and tested for high stability, reliability and quality requirements of automotive applications. The accelerometer has extremely stable output over wide range of temperature, humidity and mechanical noise. The component is qualified against AEC-Q100 standard and has several advanced self diagnostics features. The DFL housing is suitable for SMD mounting and the component is compatible with RoHS and ELV directives.

SCA2120-D07 is a part of VTI digital accelerometer family and fully compatible with single axis accelerometers (SCA800 series) and other multi axis accelerometers (SCA2100 series and SCA3100 series).

Performance Characteristics

V_{dd}=3.3 V and ambient temperature unless otherwise specified.

Parameter	Condition				
		Min	Typ	Max	Units
Analog and digital V _{dd}		3.0		3.6	V
Current consumption	Active mode		3	5	mA
	Power down mode		0.05		mA
Measurement range	Measurement axes (YZ)	-2		2	g
Operating temperature		-40		125	°C
Offset total error ^{A)}	Temperature range -40 ... +125 °C	-70		70	mg
Offset temperature dependency ^{B)}	Temperature range -40 ... +125 °C	-50		50	mg
Sensitivity	12 bit output		900		Count/g
Total sensitivity error		-4		4	% FS
Linearity error	+1g ... -1g range	-20		20	mg
	+2g...+1g, -1g...-2g	-40		40	mg
Cross-Axis sensitivity				±3.5	%
Zero acceleration output	2-complement		0		Counts
Amplitude response ^{C)}	-3dB frequency	30		55	Hz
Noise				5	mg RMS
Power on setup time				0.1	s
Output data rate			2000		Hz
Output load				50	pF
SPI clock rate				8	MHz
ESD protection	Human Body Model			2	kV
	Charge Device Model			1	kV
Moisture sensitivity level	IPC/JEDEC J-STD-020C, Level 3				
Mechanical shock				20 000	g
ID register value	Customer readable ID register (27hex)		87		

- A) Includes offset deviation from 0g value including calibration error and change over lifetime, temperature and supply voltage.
 B) Offset dependency due to temperature. Value is a relative value and has not to be centered to zero.
 C) See figure 4.

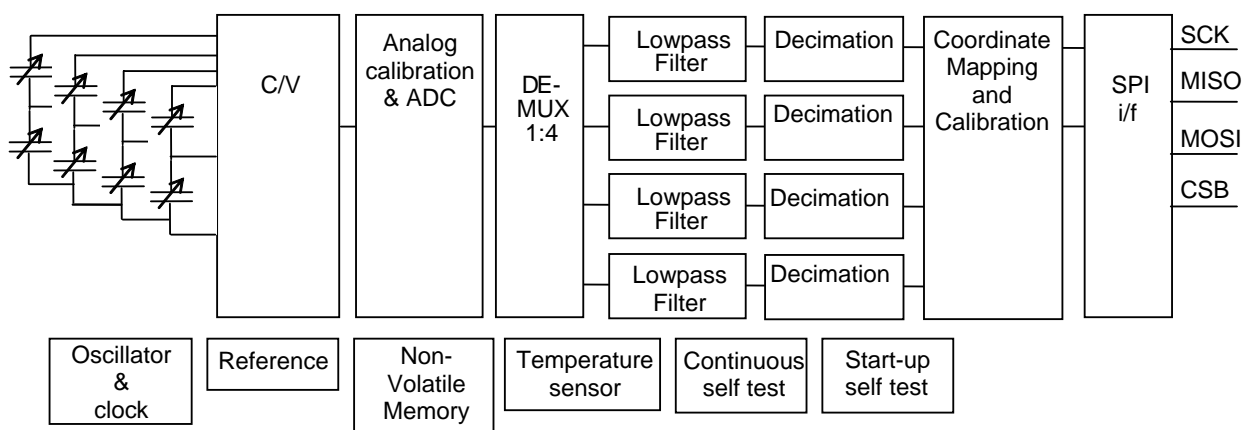

Figure 1. SCA2120-D07 Block diagram

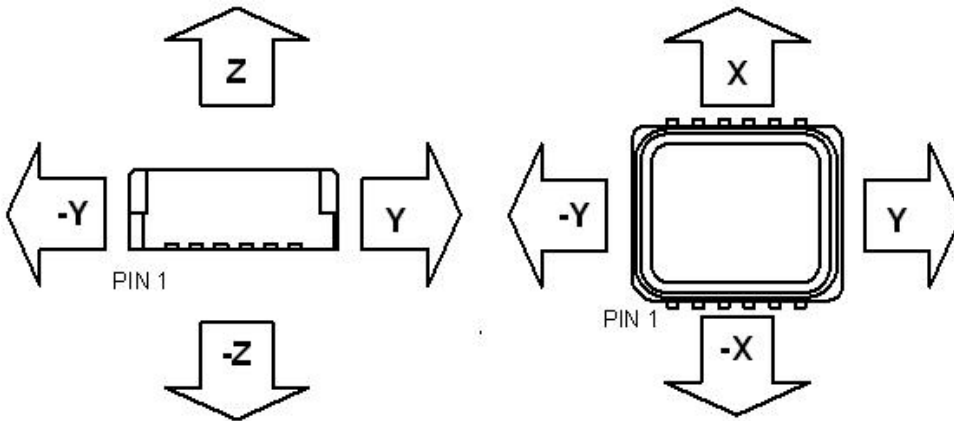

Figure 2. Accelerometer measuring directions

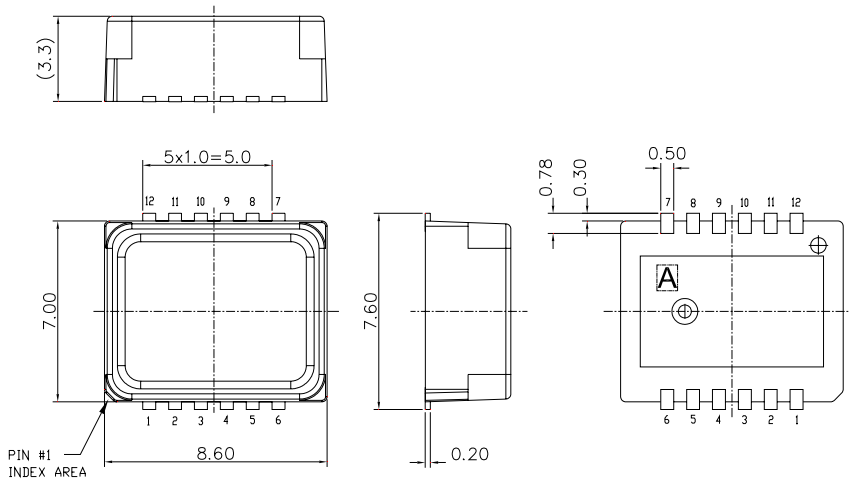

Figure 3. Housing dimensions

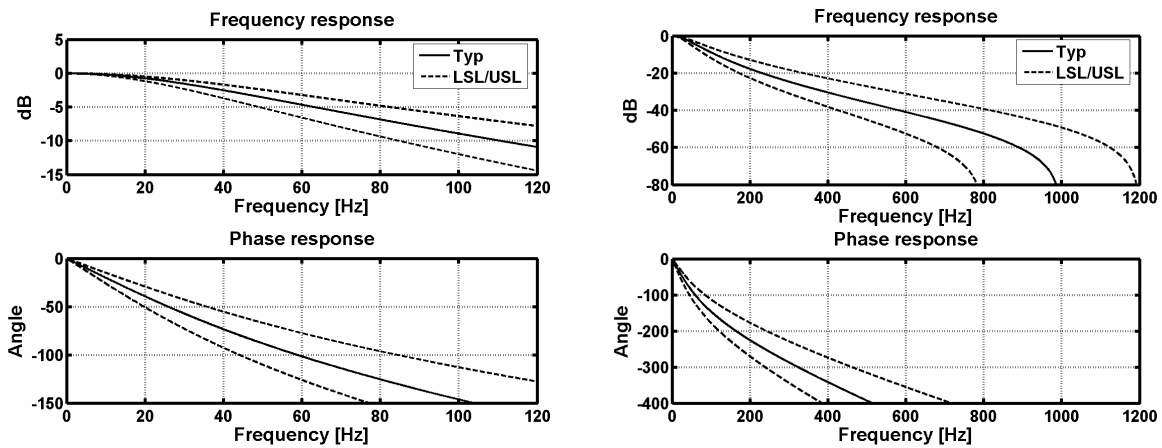

Figure 4. Frequency and phase response curves