

CMA3000 Assembly Instructions

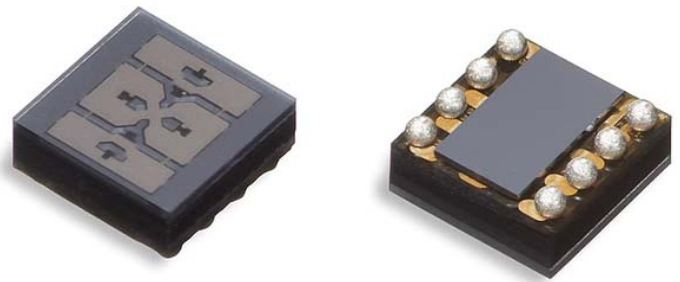

CMA3000 Series
3-axis accelerometer

TABLE OF CONTENTS

1	Objective	3
2	VTI's 3D Stacked Wafer Level Chip-on-MEMS Package (CoM)	3
3	CMA3000 CoM Package Outline and Dimensions	4
4	Packing	6
4.1	Tape and Reel Specifications	6
4.2	Reel packing and outer box	8
5	Printed Wiring Board (PWB) Level Guidelines	9
5.1	PWB layout	9
5.2	Solder Paste	10
5.3	Stencil	10
5.4	Paste Printing	11
5.5	Component Picking	11
5.6	Component Placement	11
5.7	Reflow Soldering.....	11
5.8	Moisture sensitivity level (MSL) classification.....	13
5.9	Inspection	13
6	Rework Guidelines	15
6.1	Preparations	15
6.2	Component removal	15
6.3	PWB cleaning	15
6.4	Component reuse	15
6.5	Applying flux or solder paste	15
6.6	Component placement	16
6.7	Reflow soldering	16
7	Hand Soldering Guidelines	16
8	Environmental Aspects	16
9	Effect of the Reflow Soldering	16
10	References	18
11	Document Revision History	18

1 Objective

This document describes guidelines for Printed Wiring Board (PWB) design and assembly of the CMA3000 3-axis Accelerometer. It also aims to help customers achieve the optimum soldering process.

2 VTI's 3D Stacked Wafer Level Chip-on-MEMS Package (CoM)

CMA3000 features a novel packaging concept, which is called Chip-on-MEMS (CoM). Its approach has been to maintain the benefits of manufacturing the MEMS devices and ASICs on separate wafers. For this Chip-on-MEMS concept, ASIC chips are flip-chipped onto the MEMS wafer in known good locations. Redistribution and isolation layers are applied to the MEMS wafer, solder spheres are provided for external connection before the ASICs are added and the MEMS and ASIC chips are then isolated using a passivation layer. The concept is illustrated in Figure 1.

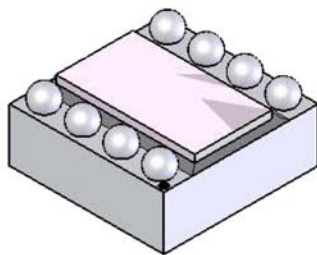

Figure 1. The concept of the CMA3000 component.

CoM-technology offers a variety of benefits including reduced lead inductance, an extremely small sized chip scale package, less than 1mm thin profile, low weight, excellent solderability and reworkability due to solder spheres. Because the CoM-technology represents the latest in the surface mount packaging technology, it is important that the design of the printed wiring board, as well as the assembly process, follow the suggested guidelines outlined in this document.

It should be emphasized that these guidelines are general in nature and should only be considered as a starting point. The user must employ their actual experiences and development efforts to optimize designs and processes for their manufacturing practices and the needs of varying end-use applications.

3 CMA3000 CoM Package Outline and Dimensions

The outline and dimensions for the CMA3000 CoM package are presented in Figure 2. Note: Solder sphere surfaces may contain marks originated from the calibration process. However, these are not considered damage and they do not have an effect on solderability.

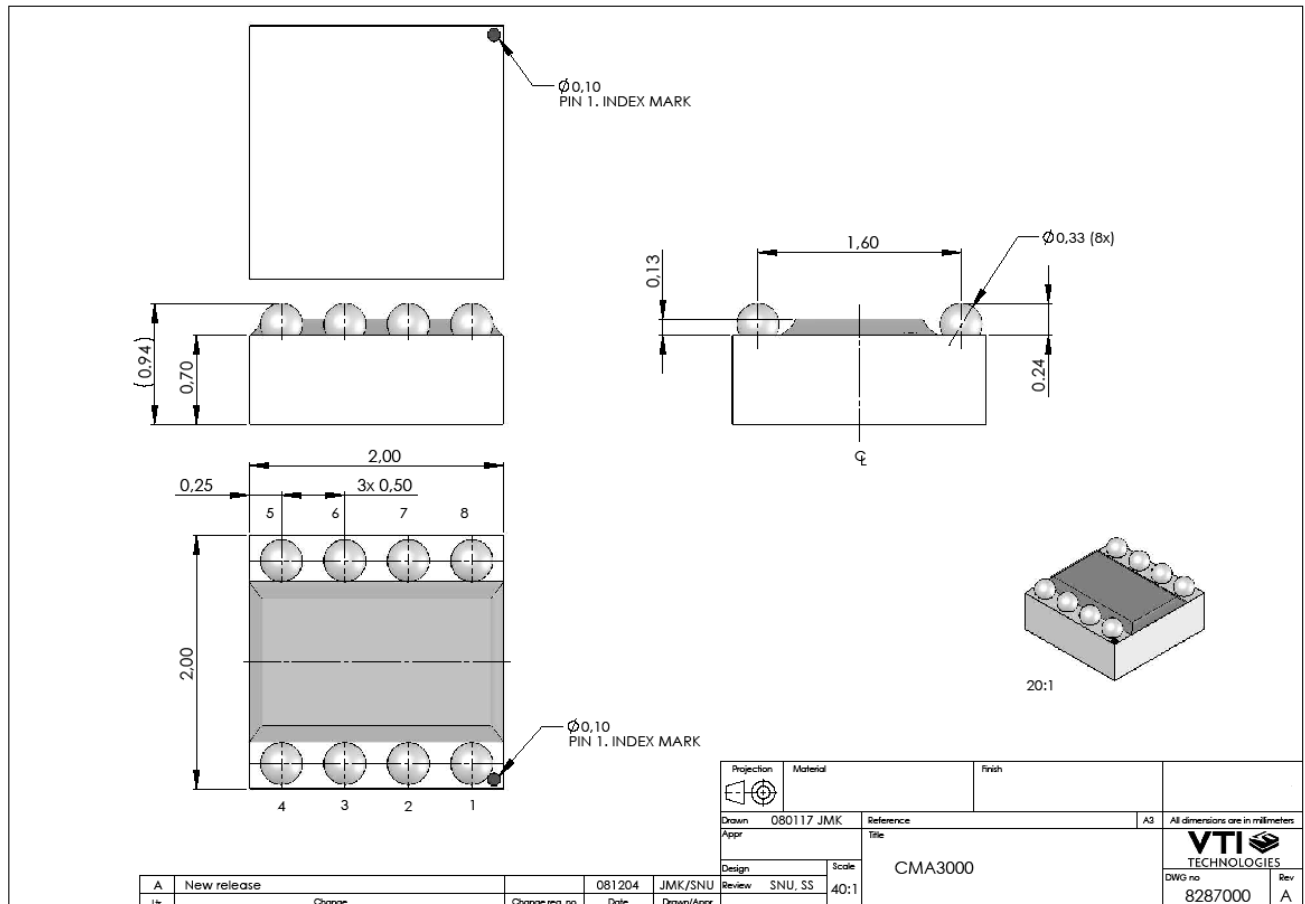

Figure 2. Outline and dimensions for the CMA3000 component mm with $\pm 50 \mu\text{m}$ tolerance for reference only. Please check the corresponding data sheet for details.

Pin 1 index mark can be seen in Figure 3. Please note that due to small size, index mark can't be seen without magnification. The use of microscope or equivalent piece of equipment is recommended.

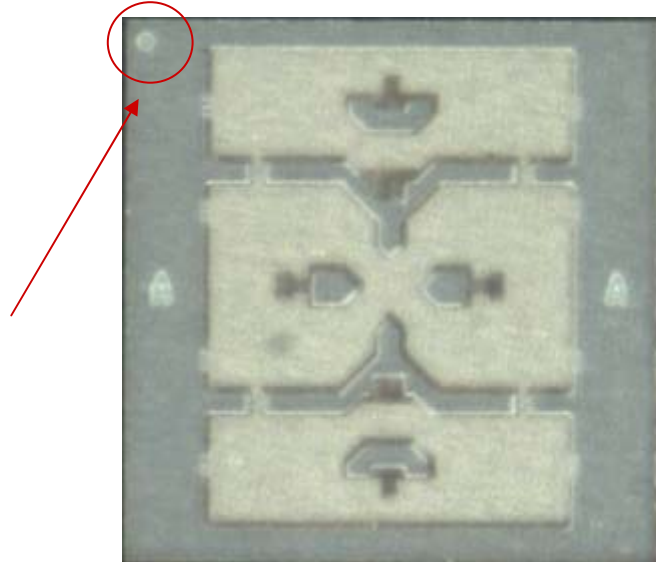
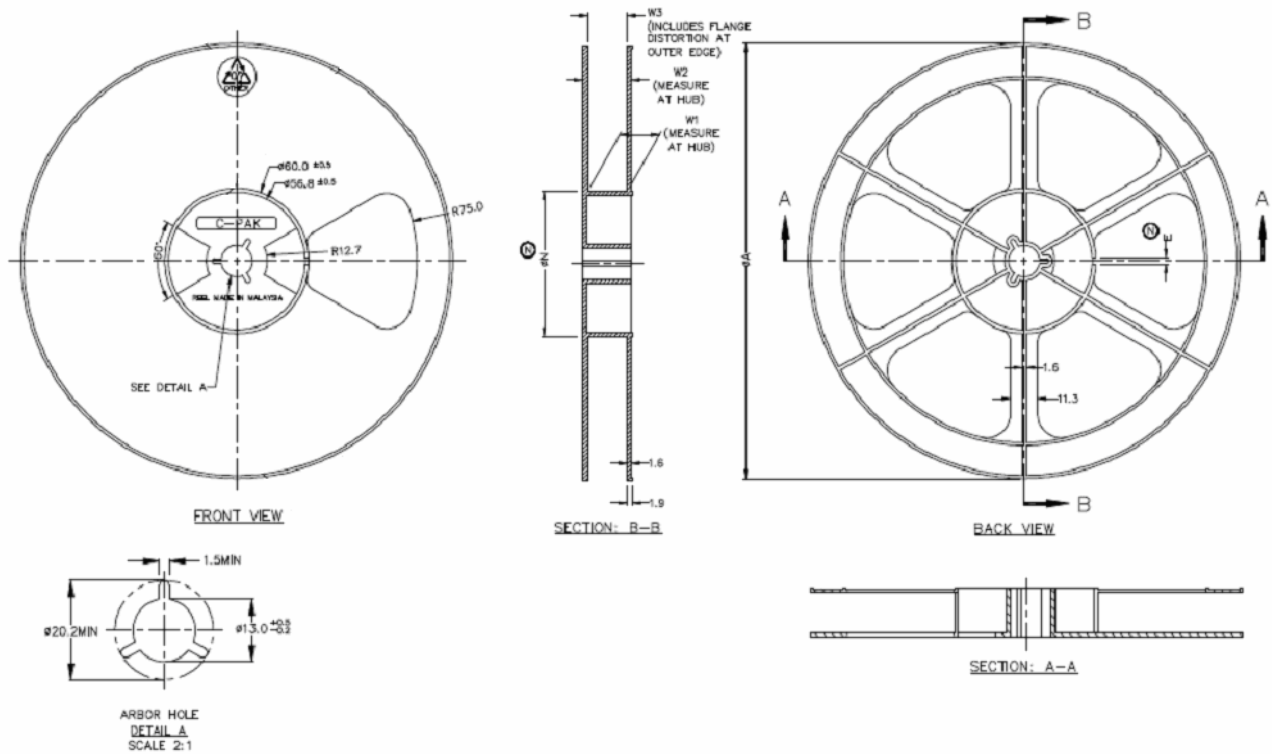

Figure 3. Pin 1 index mark on top of CMA3000.

4 Packing

4.1 Tape and Reel Specifications

- Carrier Tape TW014401 width 8.00 +0.30 mm / -0.10 mm
- Cover Tape 3M 2678, width 5.4 mm
- Polystyrene Reel, 180 mm diameter



TAPE WIDTH	A	N	W1	W2 (max)	W3	E
8	180	60	8.4	14.4	8.4	4
	-2	± 2	+1.5 -0.0		+2.5 -0.5	± 0.1

Figure 4. Reel dimensions [mm].

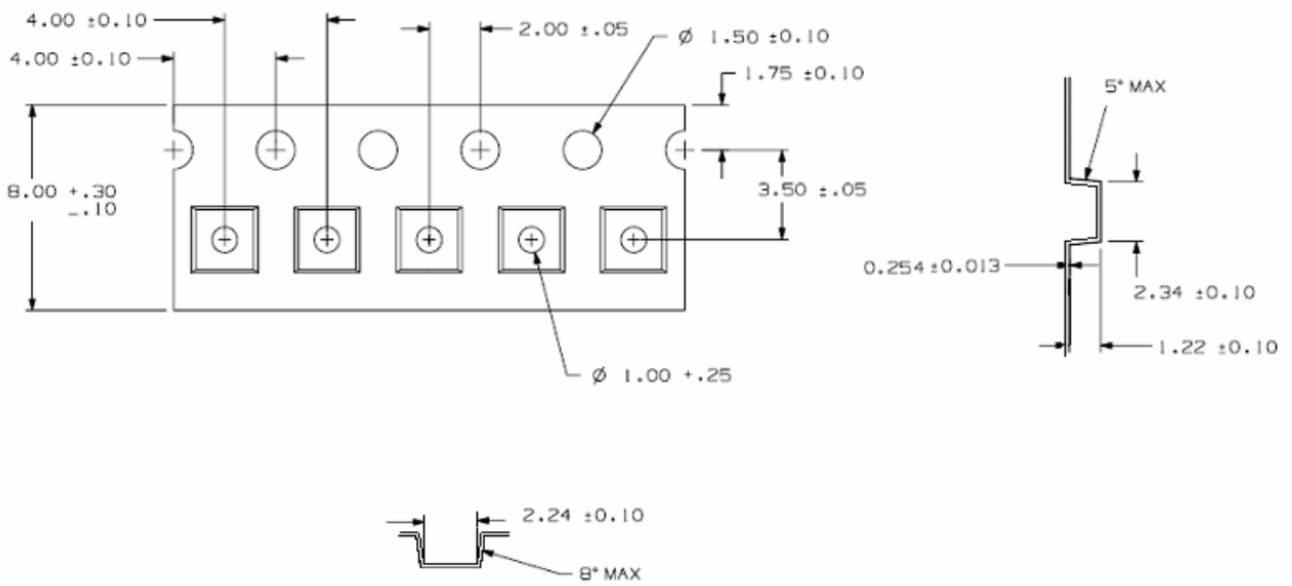

Figure 5. Tape dimensions [mm].

The polarity of the part on tape looks as follows:

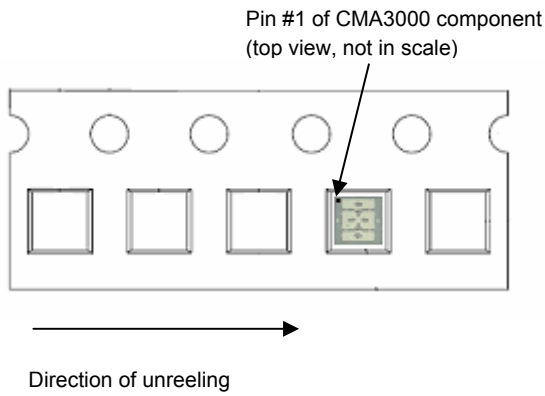

Figure 6 CMA3000's orientation on a tape.

4.2 Reel packing and outer box



Figure 7 Reel packing and outer box

5 Printed Wiring Board (PWB) Level Guidelines

5.1 PWB layout

Two types of land patterns are generally used for surface mount packages:

- 1) Non-Solder Mask Defined Pads (NSMD)
- 2) Solder Mask Defined Pads (SMD).

NSMD pads have an opening which is larger than the pad itself, and SMD pads have a solder mask opening that is smaller than the metal pad on PWB. NSMD is preferred since the copper etching process has tighter process control compared to the solder mask process and less solder mask originated defects. Symmetrical pad and trace designs on the CMA3000 component PWB area are highly recommended as those would guarantee an optimal component performance. Moreover, traces should not be routed beneath the CMA3000 component, but to use ground plane instead in order to optimize immunity to noise coupled from signal lines. Recommended PWB land pattern and dimensions for the CMA3000 component are presented in Figure 8. Reference layouts are presented in corresponding product family specifications: CMA3000 D0X_Product_Family_Specification_8281000 and CMA3000-A0X_Product_Family_Specification_8282100.

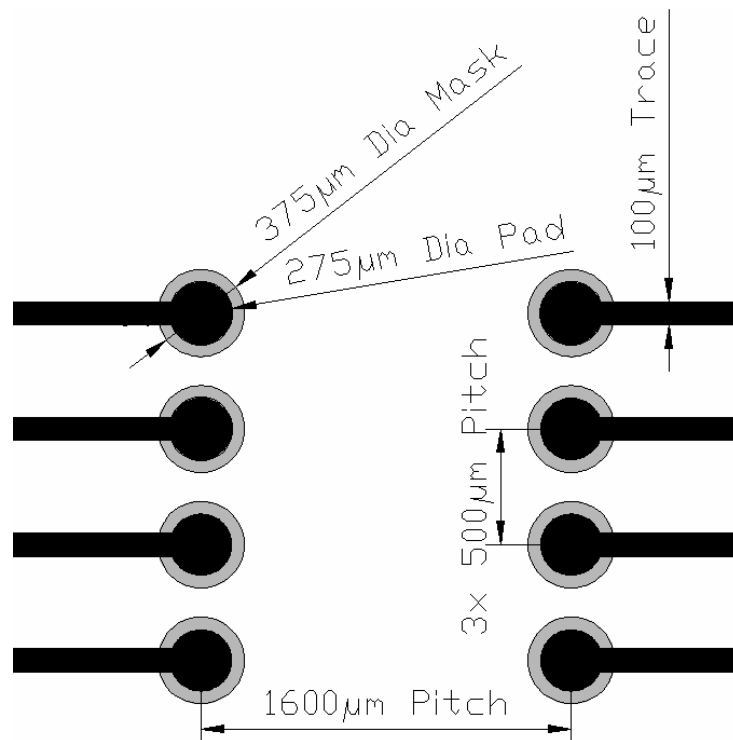

Solder Pad	Copper Pad	Solder Mask Opening	Trace Width
Non-Solder-Mask Defined (NSMD)	275 µm (+0, -25 µm)	375 µm (+0, -25 µm)	100 µm (±25 µm)

Figure 8. Recommended PWB pad layout and dimensions for CMA3000 component.

VTI Technologies' acceleration sensors can be soldered on commonly used substrates, e.g. FR-4, ceramic, flex-print etc. The pad metallization should be solder wettable in order to assure good quality solder joints. Generally used circuit board finishes for fine pitch SMD soldering are NiAu, OSP, I-Sn, and I-Ag.

5.2 Solder Paste

For the optimum metallurgical compatibility, it is recommended to solder the CMA3000 component with lead-free SAC-based (tin-silver-copper) solder paste as the solder spheres on the CMA3000 component are based on this alloy. A near eutectic solder paste composition is recommended. The melting point of lead-free SAC solder can vary between 217–221°C, depending on the composition of the solder alloy. A no-clean solder paste is recommended as **ultrasonic agitation wash of the CMA3000 component is prohibited**. The solder paste must be suitable for printing it through the stencil aperture dimensions. Type 3 paste is recommended (grain size 25-45µm).

5.3 Stencil

The solder paste is applied onto the PWB by using stencil printing. The stencil thickness and aperture determines the precise volume of solder paste deposited onto the land pattern. Stencil alignment accuracy and consistent solder volume transfer are important parameters for achieving uniform reflow soldering results. Too much solder paste can cause bridging and too little solder paste can cause insufficient wetting. Generally the stencil thickness needs to be matched to the needs of all components on the PWB. The recommended stencil openings and dimensions for the CMA3000 component are presented in Figure 9.

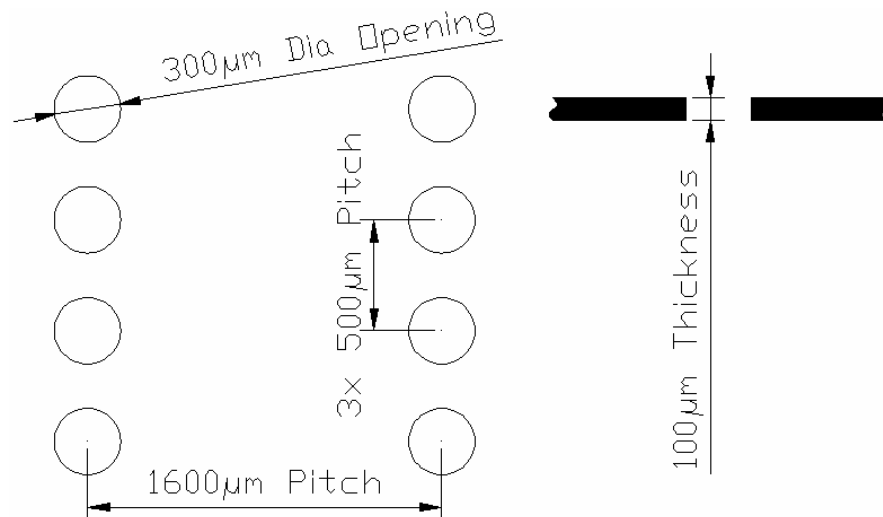

Stencil opening	Stencil thickness
Round 300 µm (+0, -25 µm)	100 µm (±25 µm)
Square 275 µm x 275 µm (±0 µm)	100 µm (±25 µm)

Figure 9. Recommended stencil openings and dimensions for CMA3000 component. Round openings are preferred.

Note that the stencil openings should always be matched to the selected PWD pad design and solder paste type for the optimal solder paste release. Furthermore, the stencil material and method of forming those have an effect on solder paste release.

5.4 Paste Printing

The paste printing speed should be adjusted according to the solder paste specifications. Care should be taken during paste printing in order to ensure correct paste amount, shape, position, and other printing characteristics. Neglecting any of these can cause open solder joints, bridging, solder balling, or other unwanted soldering results.

5.5 Component Picking

The CMA3000 component can be picked from the carrier tape using vacuum nozzles. Pick up nozzles are available in various sizes and shapes to suit a variety of different component geometries. It is recommended that different pick up nozzles are tested to find the best one suited for the purpose. The polarity of the part on tape is presented in section 4.1.

In case manual handling of the CMA3000 component is required, special attention should be paid on the handling procedures. Delicate handling is a necessity as exposed silicon and glass surfaces on the CMA3000 component are very sensitive to mechanical handling. Handling with metallic tweezers should be forbidden. However, manual handling is not recommended.

5.6 Component Placement

The CMA3000 components must be placed onto PWB accurately according to their geometry. Reflowable solder spheres provide self-alignment for the component, which will help with accurate positioning. Positioning the packages manually is not recommended.

Placement can be done with typical automatic component pick & place machinery capable of placing similar sized components. Recognition of the packages automatically by a vision system enables correct centering of the packages. The Z placement should be carefully controlled as too high force or overdriving during the component placement may damage the component and cause misalignment. Maximum assembly force is 4 N. Locally the mounting pressure should not exceed 1 MPa.

5.7 Reflow Soldering

A forced convection reflow oven is recommended to be used for soldering CMA3000 components. The reflow profile used for soldering the CMA3000 should always follow the solder paste manufacturer's specifications and recommended profile. The ramp-up rate should typically be less than 3°C/second. The reflow maximum peak temperature (measured from the component body) should not exceed 260°C and the minimum temperature (measured from the solder joints) should be higher than 230°C. The ramp down rate should be 6°C/second max. Figure 10 presents a general forced convection reflow solder profile with the typical phases of a reflow process. Please refer to IPC/JEDEC J-STD-020C table 5-2 and figure 5-1 for details. Recommended max number of reflow cycles is 3.

Profile Feature	Sn-Pb Eutectic Assembly	Pb-Free Assembly
Average Ramp-Up Rate (T _{smax} to T _p)	3 °C/second max.	3° C/second max.
Preheat		
– Temperature Min (T _{smin})	100 °C	150 °C
– Temperature Max (T _{smax})	150 °C	200 °C
– Time (t _{smin} to t _{smax})	60-120 seconds	60-180 seconds
Time maintained above:		
– Temperature (T _L)	183 °C	217 °C
– Time (t _L)	60-150 seconds	60-150 seconds
Peak/Classification Temperature (T _p)	See Table 4.1	See Table 4.2
Time within 5 °C of actual Peak Temperature (t _p)	10-30 seconds	20-40 seconds
Ramp-Down Rate	6 °C/second max.	6 °C/second max.
Time 25 °C to Peak Temperature	6 minutes max.	8 minutes max.

Note 1: All temperatures refer to topside of the package, measured on the package body surface.

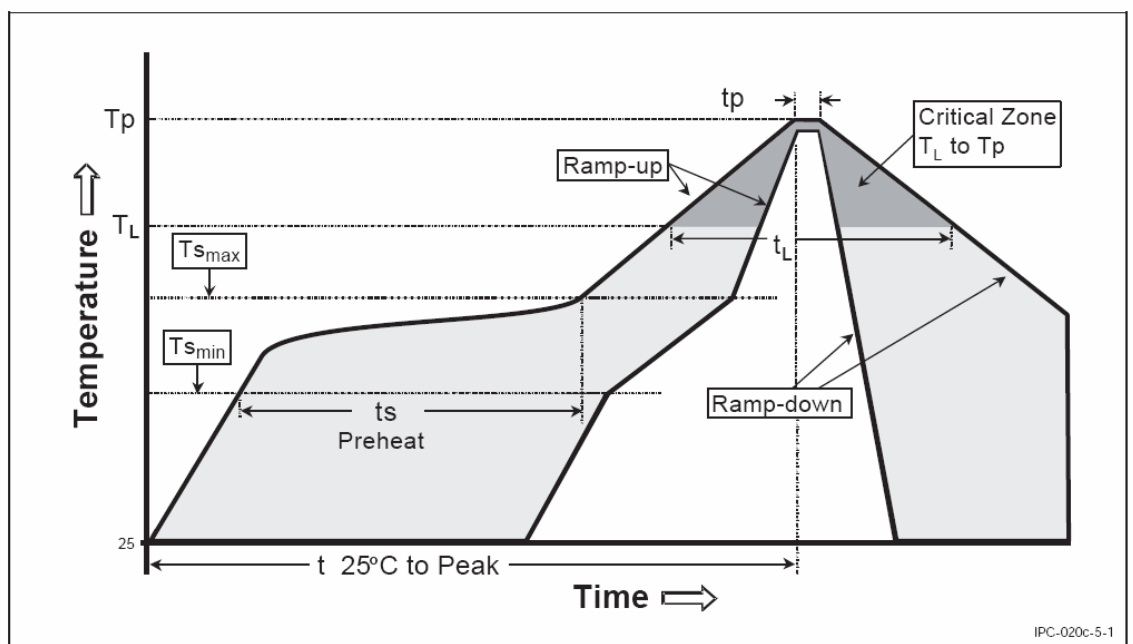

Figure 10. Typical convection reflow soldering phases and profile (IPC/JEDEC J-STD-020C table 5-2 and figure 5-1).

The process window for lead-free soldering is narrower than for traditional eutectic SnPb solders. Thus, caution has to be taken care when adjusting the reflow profiles. The reflow profile should be measured using a thermo-couple measurement system. It is recommended that at least three thermo-couples are used, depending on the application. As a general guide, one thermo-couple should be placed under a component having the largest thermal mass, one next to the smallest component, one should be in contact with CMA3000 component's solder joint, and others to the appropriate spots on a circuit board, e.g. corner, center, bottom of the board etc. The reflow profile should be adjusted according to the measured data so that each solder joint experiences an optimal reflow profile. **The temperature gradient should be as small as possible across the circuit board and the components. Extreme caution has to be taken if the circuit board contains components with vastly different thermal masses.**

Underfilling of the CMA3000 is not recommended. This can affect on the component performance.

PRELIMINARY

Subject to changes
TN68

5.8 Moisture sensitivity level (MSL) classification

The Moisture Sensitivity Level of the CMA3000 component is Level 2 according to the IPC/JEDEC J-STD-020D. The part is delivered in a dry pack. The manufacturing floor time (out of bag) at the customer's end is 1 year. Maximum soldering peak temperature for the CMA3000 component is 260°C and maximum time above 255°C is 30sec, measured from the package body, as specified in IPC/JEDEC J-STD-020D.

5.9 Inspection

The CMA3000 component's solder joint quality can be inspected with similar methods as any other solder sphered SMD component. Optical and visual inspection can be done only partly, since the solder spheres are located beneath the component. However, the visual inspection is recommended for checking the proper alignment and level of the component. X-ray inspection is recommended for checking voids, solder bridges, and short-circuits between the solder joints. Cross-sectional analysis is also an approved method for inspection of metallurgical integrity and wettability of the solder joints. An example of properly soldered CMA3000 component is illustrated in Figure 10.

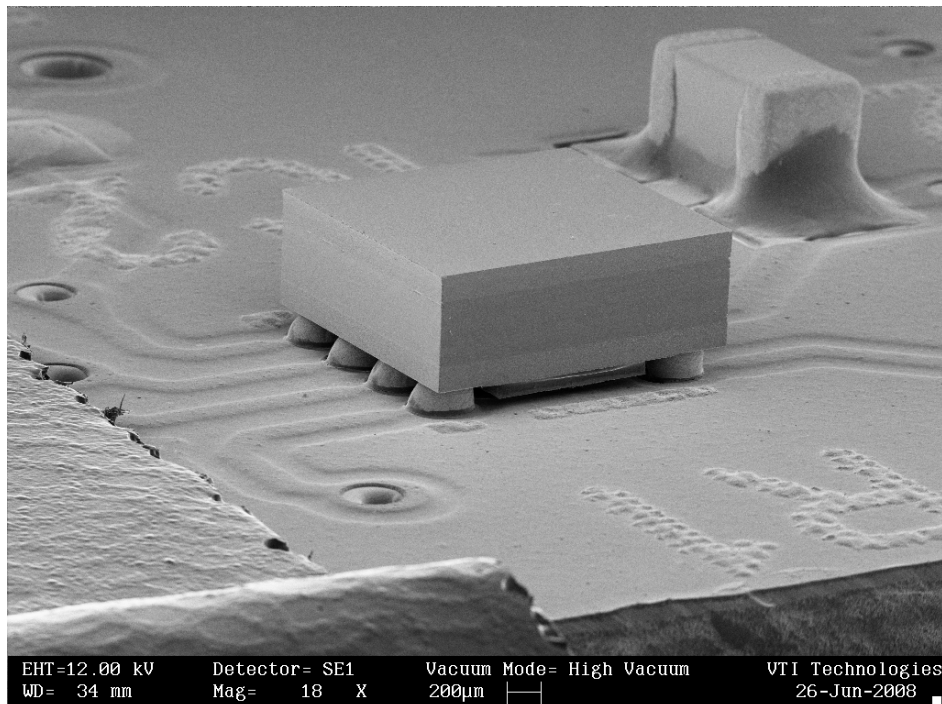

Figure 11. SEM-image of a properly soldered CMA3000 component.

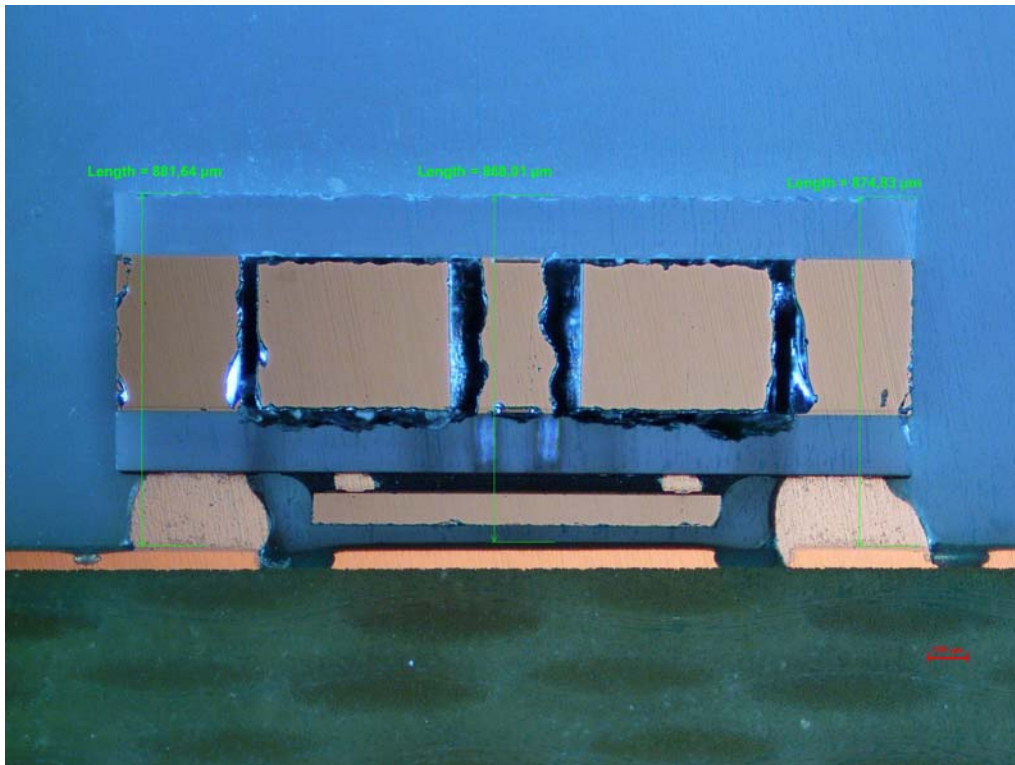

Figure 12. Cross section image of a properly soldered CMA3000 component.

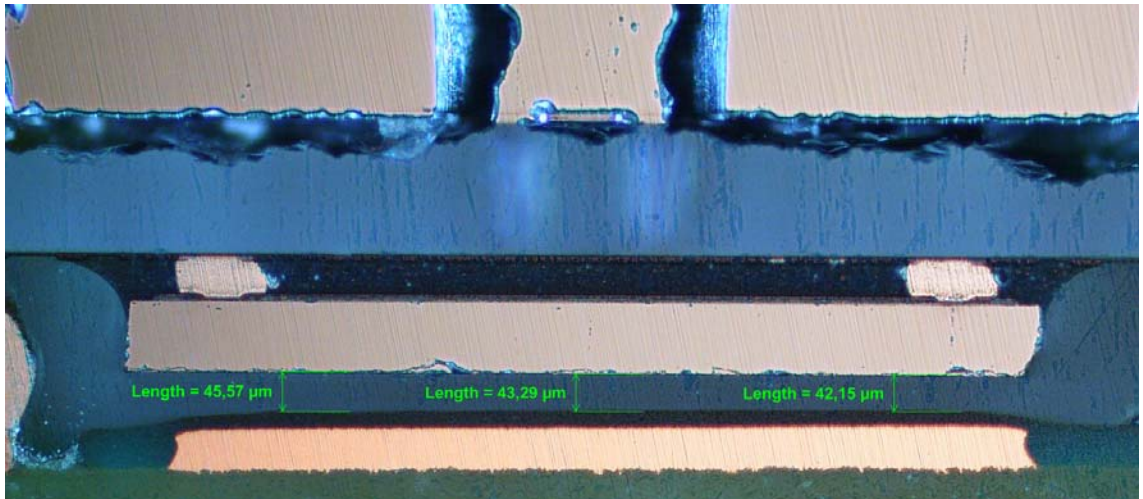

Figure 13. Gap between the component and the PWB.

6 Rework Guidelines

There are several rework systems on the market. Some will heat solder joints directly from the sides of component package, while others will direct heat on the top of component. Occasionally, very rough rework methods are used such as hand placement and heating with a soldering iron. However, these rough methods are not recommended for CMA3000 component. It is recommended that the heat flow of hot-air convection directed at the edge and under the component body directly to the solder joints and component pad areas would be used. Secondary methods include a horizontal flow method, a conduction method, and a conduction heating from the top of the package.

6.1 Preparations

Prior to the rework process, PWBs and components should be free from moisture. If necessary, baking and drying processes should be performed.

The reflow profile for the component removal should be similar to the normal reflow process. A carefully adjusted reflow profile is essential for the successful rework operation. A proper reflow profile should be measured with thermo-couples. During the reflow profiling, at least the solder joints, the top of the component, and the bottom of the PWB should be monitored. If there are other components near the component to be reworked, the temperatures of those should also be monitored. The bottom side heating of the PWB is recommended in order to reduce the PWB warpage during the rework operation.

6.2 Component removal

Once the solder joints have been fully melted, the component can be carefully removed from the PWB. The common rework methods for the component removal can be used, i.e. a vacuum nozzle etc. It is absolutely necessary to ensure the complete melting of the solder joints before the component lifting. If the solder joints are not fully melted before the lifting operation, pad damage may occur on the PWB and the component.

6.3 PWB cleaning

After the component is removed, the pad areas of the PWB should be cleaned using common rework methods. These include the applying of a rework flux, an excess solder and flux removal using a vacuum solder removal tool or a solder wick and a soldering iron with a wide chisel tip, and the cleaning of solder pads with alcohol and brush. The PWB cleaning process should be performed gently as too high force or a scrubbing motion can cause pad lifting and trace damage.

6.4 Component reuse

It is not recommended to reuse the component.

6.5 Applying flux or solder paste

Prior to the placement of a replacement component onto the reworked PWB, solder paste or flux should be applied onto the cleaned PWB pads. Recommended methods for applying solder paste or flux are the usage of a micro-stencil or dispensing. If the micro-stencil is used, it should be cleaned after each paste application to prevent clogging. For the solder paste and the stencil, the same guidelines as for the normal reflow process should be used. The usage of solder paste over mere flux is recommended due to an increased stand-off.

6.6 Component placement

An accurate alignment of the component is an important process step although the surface tension of the solder during the reflow step will help with the self-alignment. The use of a split-vision alignment system is recommended to ensure the precise alignment of the component to the PWB. The Z placement force should be carefully controlled in order to prevent the solder bridging, component damage and misalignment.

6.7 Reflow soldering

The same reflow profile, as for the component removal, can be used for the re-attachment of the replacement component as long as all solder joints will fully melt and properly wet the contact areas. Otherwise, a new and proper reflow profile must be developed and measured from the solder joints. Note that the reflow profile is always solder paste and flux dependent. The reworked PWBs should be allowed to cool to the room temperature. The PWBs and the components should be inspected after the rework process for possible defects. The use of X-ray inspection techniques can be used to verify the success of the rework process.

7 Hand Soldering Guidelines

Hand soldering of the CMA3000 component with soldering iron is not recommended. For prototypes of the CMA3000 component, VTI can provide pre-assembled component on a PWB. For more information on this, please find the document CMA3000-D0X PWB specification 8287500A and CMA3000-D0X PWB specification 8287600A. These can be found from the Internet at www.vti.fi.

8 Environmental Aspects

VTI Technologies respects environmental values and thus its CoM packaged accelerometer sensors are lead-free and RoHS compatible. VTI Technologies' sensors should be soldered with lead-free solders in order to guarantee full RoHS compatibility.

9 Effect of the Reflow Soldering

CMA3000 is a factory calibrated three-axis accelerometer. However, reflow soldering may cause acceleration offset shift due to thermal stress induced to the component. Offset shift depends e.g. on the used layout design, circuit board material and the manufacturing process. Offset shift stabilizes typically in 6 h after the reflow and is typically less than 150 mg (1σ). Calibration is not recommended prior the offset has settled.

Typical offset settling behavior after the soldering can be seen in Figure 14 below.

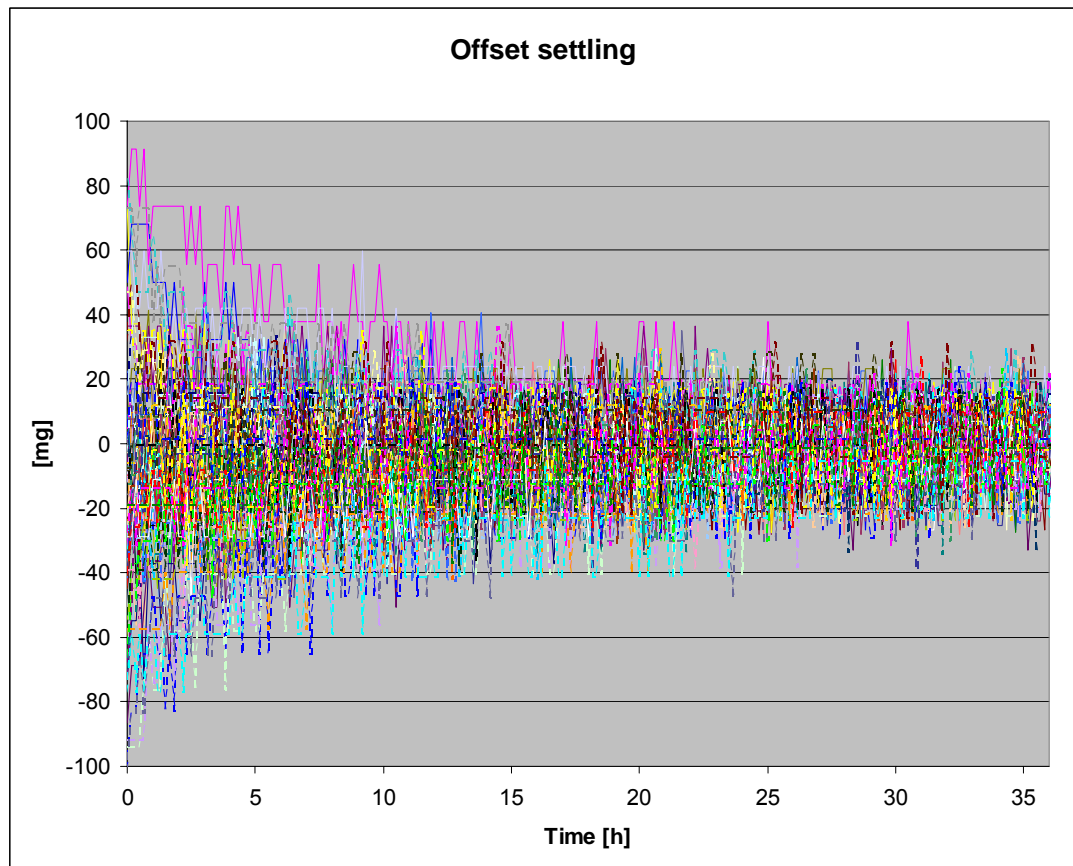

Figure 14 Offset settling (N=96) after the reflow

10 References

JEDEC / Electronic Industries Alliance, Inc. Moisture/Reflow Sensitivity Classification for Nonhermetic Solid State Surface Mount Devices (J-STD-020D).

11 Document Revision History

Version	Date	Change Description
0.1	24.01.2008	Initial preliminary release
0.2	29.2.2008	Minor updates
0.3	01.07.2008	Minor updates
0.4	07.07.2008	Minor updates
0.5	10.12.2008	Minor updates
0.6	29.12.2008	Version for launch
0.7	17.6.2009	Packing information added, effect of reflow section 9 updated
0.8	29.6.2009	Recommended max number of reflow cycles (3) added, fig 10 replaced with the one from standard, reference to JEDEC std reflow profile added.
0.9	4.8.2009	Note on the index mark visibility added in p5

VTI Technologies reserves all rights to modify this document without prior notice.